

# Endeavor™ Line RP15AZ Series iM Heat Pumps



## RP15AZ

Cooling Efficiencies up to: 16 SEER2 / 11.7 EER2

Heating Efficiencies up to: 8.1 HSPF

Nominal Sizes: 1.5 to 5 Tons [5.3 to 17.6 kW]

Cooling & Heating Capacities: 13.36 kBTU to 45.6 kBTU



9001:2015



*\*Proper sizing and installation of equipment is critical to achieve optimal performance. Split system air conditioners and heat pumps must be matched with appropriate coil components to meet Energy Star. Ask your Contractor for details or visit [www.energystar.gov](http://www.energystar.gov).*

## Table of Contents

Features & Benefits .....	3
Model Number Identification .....	4
General Data/Electrical Data .....	5
Accessories .....	6
Weighted Sound Power .....	6
Unit Dimensions .....	7
Clearances .....	8
Refrigerant Line Size Information .....	9-10
Performance Data .....	11
Limited Warranty .....	12

## Features and Benefits

- **Two-Stage Scroll Compressor:** Features two speeds (high and low) of cooling and heating, providing more precise temperature control, lower humidity and greater efficiency when compared to single stage compressors
- **7 mm Condenser Copper Coil<sup>1</sup>:** Requires less refrigerant allowing for a smaller and lighter footprint while enhancing reliability
- **Inverted Reversing Valve:** Allows for faster heat transfer with gravity assist shifting and reduced joint stress for increased reliability
- **PlusOne® Expanded Valve Space:** 3 in. – 4 in. – 5 in. service valve space — provides a minimum working area of 27-square inches for easier access
- **PlusOne® Triple Service Access:** 15" wide, industry leading corner service access, two fastener, removeable corner and individual louver panels — makes repairs easier and faster

<sup>1</sup>Does not apply to the 5 ton model

# Heat Pumps

<u>R</u>	<u>P</u>	<u>15</u>	<u>A</u>	<u>Z</u>	<u>18</u>	<u>A</u>	<u>J</u>	<u>2</u>	<u>N</u>	<u>A</u>
Brand	Product Category	SEER2	Region	Refrigerant	Capacity	Major Series	Voltage	Type	Controls	Minor Series
	P - Heat Pump	15 - 15.2 SEER2	A - All Regions	Z - R-410A	18 - 18,000 [5.28 kW] 24 - 24,000 [7.03 kW] 30 - 30,000 [8.79 kW] 36 - 36,000 [10.55 kW] 42 - 42,000 [12.31 kW] 48 - 48,000 [14.07 kW] 60 - 60,000 [17.58 kW]	A - 1st Design	J - 208/230/1/60	2 - 2+ Stage	N - Non-Comm.	A - 1st Design

[ ] Designates Metric Conversions

AVAILABLE MODELS	DESCRIPTION
RP15AZ18AJ2NA	Endeavor™ Line 1 1/2 ton 15.2 SEER2 2-Stage iM Heat Pump-208/230/1/60
RP15AZ24AJ2NA	Endeavor™ Line 2 ton 15.2 SEER2 2-Stage iM Heat Pump-208/230/1/60
RP15AZ30AJ2NA	Endeavor™ Line 2 1/2 ton 15.2 SEER2 2-Stage Heat iM Pump-208/230/1/60
RP15AZ36AJ2NA	Endeavor™ Line 3 ton 15.2 SEER2 2-Stage iM Heat Pump-208/230/1/60
RP15AZ42AJ2NA	Endeavor™ Line 3 1/2 ton 15.2 SEER2 2-Stage iM Heat Pump-208/230/1/60
RP15AZ48AJ2NA	Endeavor™ Line 4 ton 15.2 SEER2 2-Stage iM Heat Pump-208/230/1/60
RP15AZ60AJ2NA	Endeavor™ Line 5 ton 15.2 SEER2 2-Stage iM Heat Pump-208/230/1/60

STANDARD EQUIPMENT
R-410A Refrigerant
Scroll Compressor
Field Installed Filter Drier
Front Seating Service Valves
Internal Pressure Relief Valve
Internal Thermal Overload
Long Line capability
Low Ambient capability with Kit
3-4-5 Expanded Valve Space
Composite Basepan
2 Screw Control Box Access
15" Access to Internal Components
Quick release louver panel design
No fasteners to remove along bottom
Optimized Venturi Airflow
Single row condenser coil
Powder coated paint
Rust resistant screws
QR code
External gauge ports
Service trays

<b>General Data</b>							
<b>MODEL NO.</b>	<b>(-)P15AZ 18AJ2NA</b>	<b>(-)P15AZ 24AJ2NA</b>	<b>(-)P15AZ 30AJ2NA</b>	<b>(-)P15AZ 36AJ2NA</b>	<b>(-)P15AZ 42AJ2NA</b>	<b>(-)P15AZ 48AJ2NA</b>	<b>(-)P15AZ 60AJ2NA</b>
<b>Nominal Tonnage</b>							
<b>Valve Connections</b>							
Liquid Line O.D. – in.	0.375	0.375	0.375	0.375	0.375	0.375	0.375
Suction Line O.D. – in.	0.75	0.75	0.75	0.75	0.875	0.875	0.875
<b>Refrigerant (R410A) furnished oz.<sup>1</sup></b>	118	118	120	127	143	146	220
<b>Compressor Type</b>	2-stage Scroll						
<b>Outdoor Coil</b>							
Net face area – Outer Coil	10.9	10.9	19.5	21.5	21.5	21.5	32.5
Net face area – Inner Coil	10.5	10.5					
Tube diameter – in.	0.276	0.276	0.276	0.276	0.276	0.276	0.375
Number of rows	2	2	1	1	1	1	1
Fins per inch	22	22	22	22	22	22	20
<b>Outdoor Fan</b>							
Diameter – in.	20	20	24	24	24	24	26
Number of blades	2	2	3	3	3	3	3
Motor hp	1/6	1/6	1/5	1/5	1/5	1/5	1/5
CFM	2582	2582	4077	4206	4206	4206	5106
RPM	1075	1075	850	850	850	850	850
watts	145	145	222	246	246	246	294
<b>Shipping weight – lbs.</b>	157	157	209	221	247	247	298
<b>Operating weight – lbs.</b>	150	150	202	214	240	240	291

<b>Electrical Data</b>							
<b>Line Voltage Data (Volts-Phase-Hz)</b>	<b>208/230-1-60</b>	<b>208/230-1-60</b>	<b>208/230-1-60</b>	<b>208/230-1-60</b>	<b>208/230-1-60</b>	<b>208/230-1-60</b>	<b>208/230-1-60</b>
<b>Maximum overcurrent protection (amps)<sup>2</sup></b>	15	25	30	30	45	45	50
<b>Minimum circuit ampacity<sup>3</sup></b>	11	15	18	20	26	28	31
<b>Compressor</b>							
Rated load amps	8	11	14	15	20	21	24
Locked rotor amps	56	61	87	102	151	0	151
<b>Condenser Fan Motor</b>							
Full load amps	0.75	0.75	1.0	1.0	1.0	1.0	1.0
Locked rotor amps	1.5	1.5	2.56	2.56	2.56	2.56	2.56

<sup>1</sup>Refrigerant charge sufficient for 15 ft. length of refrigerant lines. For longer line set requirements see the installation instructions for information about set length and additional refrigerant charge required.

<sup>2</sup>HACR type circuit breaker or fuse.

<sup>3</sup>Refer to National Electrical Code manual to determine wire, fuse and disconnect size requirements.

## Accessories

MODEL NO.		(-)P15AZ18	(-)P15AZ24	(-)P15AZ30	(-)P15AZ36	(-)P15AZ42	(-)P15AZ48	(-)P15AZ60
Compressor crankcase heater*		44-17402-44	44-17402-44	44-17402-44	44-17402-44	44-17402-45	44-17402-45	Factory Standard
Low ambient control		RXAD-A08	RXAD-A08	RXAD-A08	RXAD-A08	RXAD-A08	RXAD-A08	RXAD-A08
Compressor sound cover		68-23427-26	68-23427-26	68-23427-26	68-23427-26	68-23427-25	68-23427-25	68-23427-25
Compressor hard start kit		SK-A1	SK-A1	SK-A1	SK-A1	SK-A1	SK-A1	SK-A1
Low pressure control		Factory Standard	Factory Standard	Factory Standard	Factory Standard	Factory Standard	Factory Standard	Factory Standard
High pressure control		Factory Standard	Factory Standard	Factory Standard	Factory Standard	Factory Standard	Factory Standard	Factory Standard
Liquid Line Solenoid (24 VAC, 50/60 Hz)	Solenoid Valve	200RD2T3TVLC	200RD2T3TVLC	200RD2T3TVLC	200RD2T3TVLC	200RD2T3TVLC	200RD3T3TVLC	200RD3T3TVLC
	Solenoid Coil	61-AMG24V	61-AMG24V	61-AMG24V	61-AMG24V	61-AMG24V	61-AMG24V	61-AMG24V
Liquid Line Solenoid (120/240 VAC, 50/60 Hz)	Solenoid Valve	200RD2T3TVLC	200RD2T3TVLC	200RD2T3TVLC	200RD2T3TVLC	200RD2T3TVLC	200RD3T3TVLC	200RD3T3TVLC
	Solenoid Coil	61-AMG120/240V	61-AMG120/240V	61-AMG120/240V	61-AMG120/240V	61-AMG120/240V	61-AMG120/240V	61-AMG120/240V
Classic Top Cap w/Label		91-101123-21	91-101123-21	91-101123-21	91-101123-21	91-101123-21	91-101123-21	91-101123-21

\*Bi-flow kits are required when installing a liquid line solenoid on a heat pump.

## Weighted Sound Power Level (dBA)

UNIT SIZE - VOLTAGE, SERIES	STANDARD RATING (DBA)	TYPICAL OCTAVE BAND SPECTRUM (dBA without tone adjustment)						
		125	250	500	1000	2000	4000	8000
RP15AZ18A	73	58.0	58.8	62.0	62.3	59.2	56.6	50.5
RP15AZ24A	73	56.6	59.6	62.2	62.1	58.8	55.4	50.8
RP15AZ30A	72	48.9	55.3	63.6	61.0	59.1	56.5	48.7
RP15AZ36A	74	51.2	56.4	63.1	63.8	60.8	57.4	56.5
RP15AZ42A	74	56.8	58.7	65.9	66.2	62.9	59.4	54.2
RP15AZ48A	74	57.3	56.6	64.1	64.0	61.1	58.0	56.5
RP15AZ60A	74	43.9	55.2	63.4	65.8	61.7	57.9	52.9

**NOTE:** Tested in accordance with AHRI Standard 270-08 (not listed in AHRI)

## Unit Dimensions

MODEL NO.	OPERATING						SHIPPING					
	H (Height)		L (Length)		W (Width)		H (Height)		L (Length)		W (Width)	
	INCHES	mm	INCHES	mm	INCHES	mm	INCHES	mm	INCHES	mm	INCHES	mm
(-)P15AZ18AJ2NA	25.00	635.00	29.75	755.65	29.75	755.65	27.90	708.66	33.25	844.55	33.25	844.55
(-)P15AZ24AJ2NA	25.00	635.00	29.75	755.65	29.75	755.65	27.90	708.66	33.25	844.55	33.25	844.55
(-)P15AZ30AJ2NA	35.00	889.00	33.75	857.25	33.75	857.25	38.35	974.09	37.64	956.06	37.64	956.06
(-)P15AZ36AJ2NA	39.00	990.60	33.75	857.25	33.75	857.25	42.35	1075.69	37.64	956.06	37.64	956.06
(-)P15AZ42AJ2NA	39.00	990.60	33.75	857.25	33.75	857.25	42.35	1075.69	37.64	956.06	37.64	956.06
(-)P15AZ48AJ2NA	39.00	990.60	33.75	857.25	33.75	857.25	42.35	1075.69	37.64	956.06	37.64	956.06
(-)P15AZ60AJ2NA	51.00	1295.40	35.75	908.05	35.75	908.05	54.50	1384.30	39.37	1000.00	39.37	1000.00

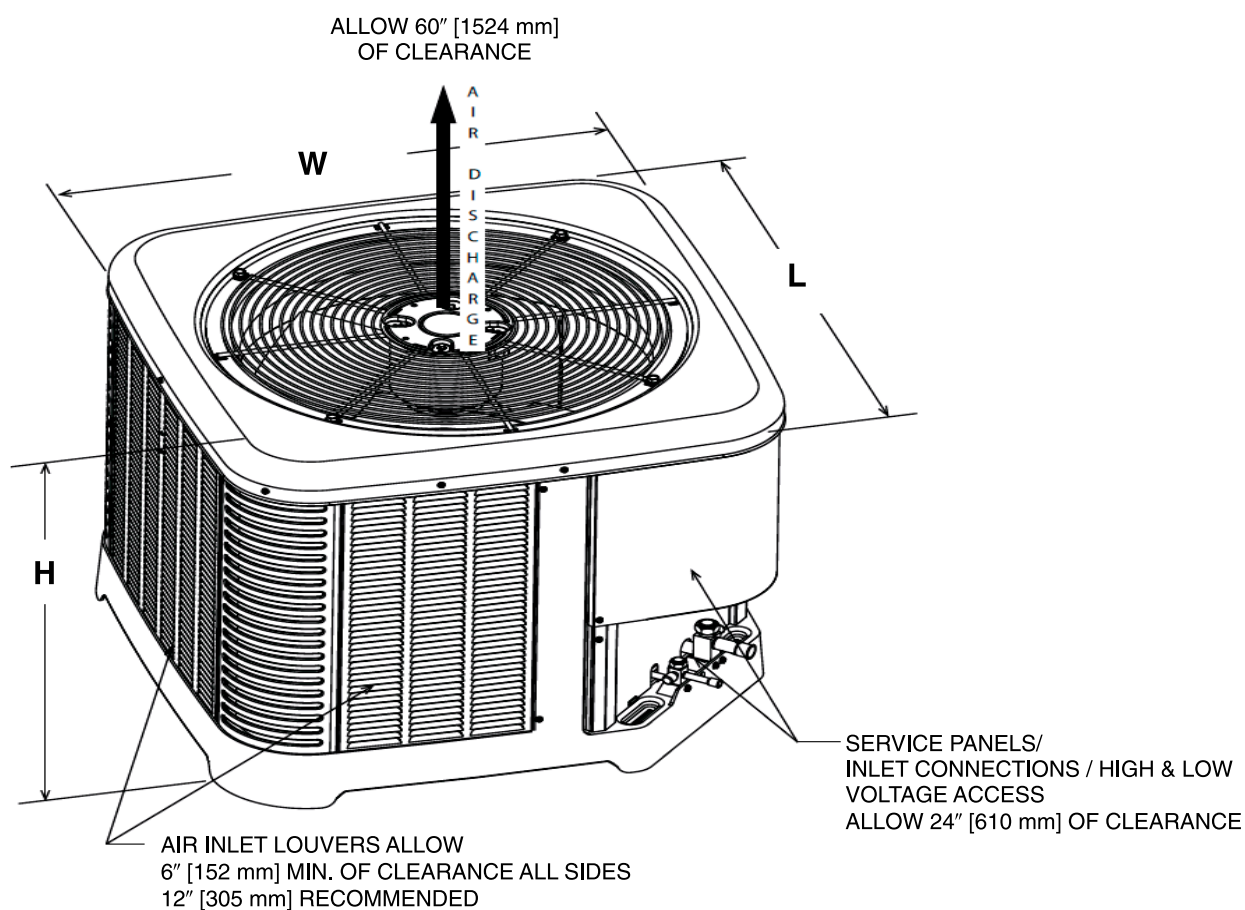

[ ] Designates Metric Conversions

ST-A1226-02-00

# CLEARANCES

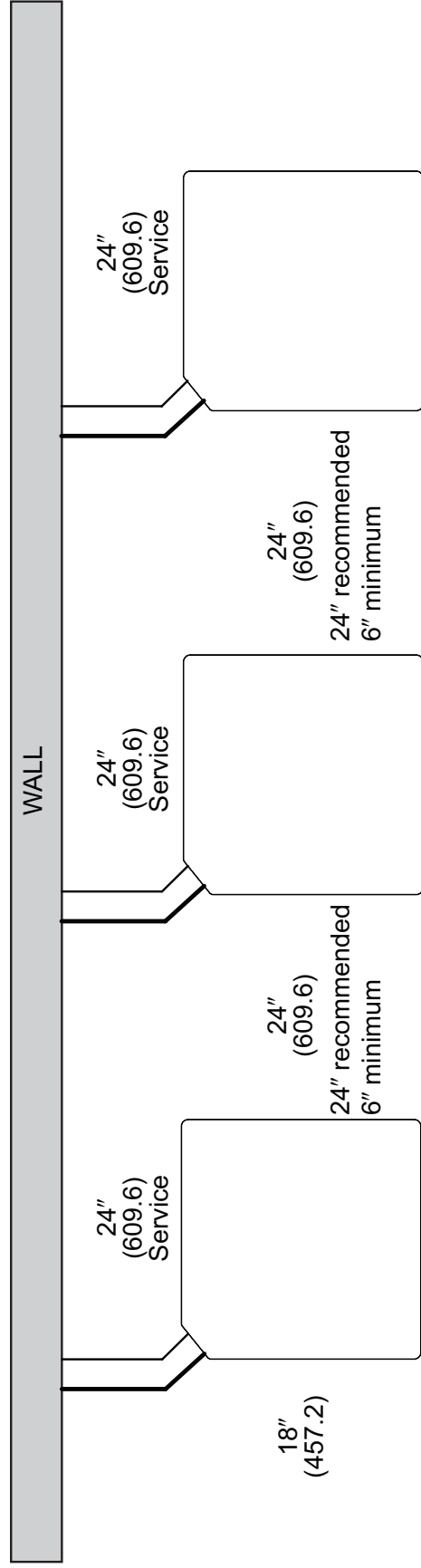
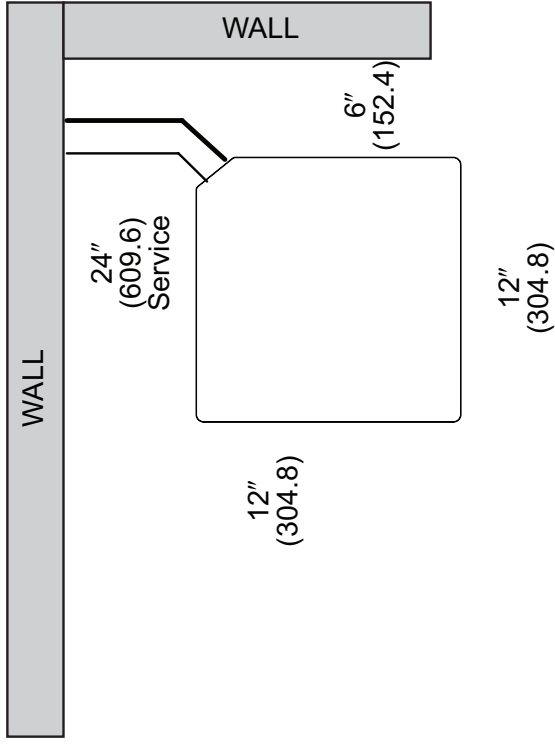
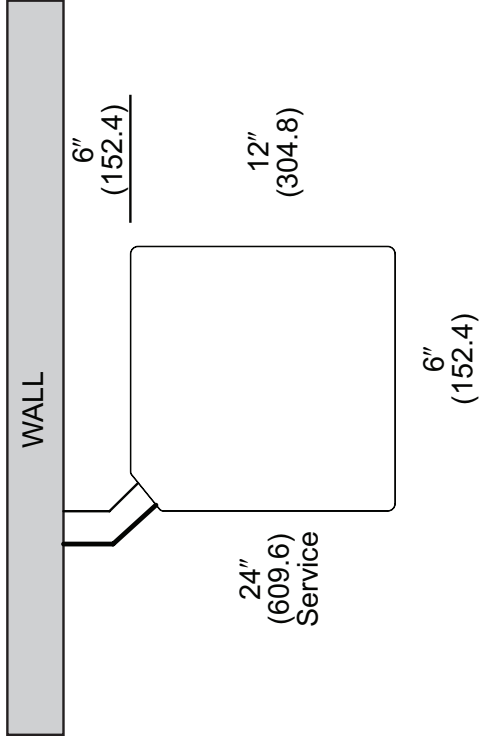

**NOTE: NUMBERS IN ( ) = mm**

**IMPORTANT:** When installing multiple units in an alcove, roof well or partially enclosed area, ensure there is adequate ventilation to prevent re-circulation of discharge air.



## Refrigerant Line Size Information

SINGLE AND TWO-STAGE HEAT PUMPS									
UNIT SIZE	MAX. LIQUID LINE SIZE	SUCTION LINE SIZE	OUTDOOR UNIT ABOVE OR BELOW INDOOR UNIT EQUIVALENT LENGTH IN FEET						
			0-15	16-25	26-50	51-80	81-100	101-125	126-150
			MAXIMUM VERTICAL SEPARATION/CAPACITY MULTIPLIER						
1.5 TON	3/8"	1/2"	15 / 1	25 / 1	50 / 0.99	80 / 0.97	100 / 0.97	115 / 0.96	115 / 0.95
		5/8"	15 / 1	25 / 1	50 / 1	80 / 0.99	100 / 0.99	115 / 0.99	115 / 0.98
		3/4"	15 / 1	25 / 1	50 / 1	80 / 0.99	100 / 0.99	115 / 0.99	115 / 0.98
2 TON	3/8"	5/8"	15 / 1	25 / 1	50 / 0.99	80 / 0.98	100 / 0.97	100 / 0.96	95 / 0.95
		3/4"	15 / 1	25 / 1	50 / 1	80 / 0.99	100 / 0.99	100 / 0.99	95 / 0.98
2.5 TON	3/8"	5/8"	15 / 1	25 / 0.99	50 / 0.98	80 / 0.97	95 / 0.96	90 / 0.94	85 / 0.93
		3/4"	15 / 1	25 / 1	50 / 0.99	80 / 0.99	95 / 0.98	90 / 0.98	85 / 0.97
3 TON	3/8"	5/8"	15 / 1	25 / 0.99	50 / 0.97	80 / 0.95	85 / 0.94	80 / 0.92	75 / 0.9
		3/4"	15 / 1	25 / 1	50 / 0.99	80 / 0.98	85 / 0.98	80 / 0.97	75 / 0.96
		7/8"	15 / 1	25 / 1	50 / 1	80 / 0.99	85 / 0.99	80 / 0.99	75 / 0.98
3.5 TON	3/8"	3/4"	15 / 1	25 / 0.99	50 / 0.98	80 / 0.97	80 / 0.97	70 / 0.96	65 / 0.95
		7/8"	15 / 1	25 / 1	50 / 0.99	80 / 0.99	80 / 0.99	70 / 0.98	65 / 0.98
4 TON	3/8"	3/4"	15 / 1	25 / 0.99	50 / 0.98	75 / 0.97	70 / 0.96	60 / 0.95	50 / 0.94
		7/8"	15 / 1	25 / 1	50 / 0.99	75 / 0.99	70 / 0.98	60 / 0.98	50 / 0.97
5 TON	3/8"	3/4"	15 / 1	25 / 0.99	50 / 0.97	65 / 0.95	45 / 0.94	30 / 0.92	15 / 0.9
		7/8"	15 / 1	25 / 0.99	50 / 0.99	65 / 0.98	45 / 0.97	30 / 0.96	15 / 0.96

**NOTES:**

- 1) Maximum Equivalent Line Length may not exceed 250'.
- 2) Maximum Actual Line Length may not exceed 200'.
- 3) Light Grey shaded areas are considered long line and may require accessories as recommended in Long Line Set Guide.
- 4) Refer to supplemental Long Line Set Guide for applications that require liquid line size other than 3/8".
- 5) **DO NOT** use suction line traps in the suction riser as this adds additional unwanted pressure drop in the system.

## Refrigerant Line Size Information (Con't.)

SINGLE AND TWO-STAGE HEAT PUMPS									
UNIT SIZE	MAX. LIQUID LINE SIZE	SUCTION LINE SIZE	OUTDOOR UNIT ABOVE OR BELOW INDOOR UNIT EQUIVALENT LENGTH IN METERS						
			0-5	5.5-8	8.5-15	15.5-24	24.5-30	30.5-38	38.5-46
			MAXIMUM VERTICAL SEPARATION/CAPACITY MULTIPLIER						
1.5 TON	3/8"	1/2"	5 / 1	8 / 1	15 / 0.99	24 / 0.97	30 / 0.97	35 / 0.96	35 / 0.95
		5/8"	5 / 1	8 / 1	15 / 1	24 / 0.99	30 / 0.99	35 / 0.99	35 / 0.98
		3/4"	5 / 1	8 / 1	15 / 1	24 / 0.99	30 / 0.99	35 / 0.99	35 / 0.98
2 TON	3/8"	5/8"	5 / 1	8 / 1	15 / 0.99	24 / 0.98	30 / 0.97	30 / 0.96	29 / 0.95
		3/4"	5 / 1	8 / 1	15 / 1	24 / 0.99	30 / 0.99	30 / 0.99	29 / 0.98
2.5 TON	3/8"	5/8"	5 / 1	8 / 0.99	15 / 0.98	24 / 0.97	29 / 0.96	27 / 0.94	26 / 0.93
		3/4"	5 / 1	8 / 1	15 / 0.99	24 / 0.99	29 / 0.98	27 / 0.98	26 / 0.97
3 TON	3/8"	5/8"	5 / 1	8 / 0.99	15 / 0.97	24 / 0.95	26 / 0.94	24 / 0.92	23 / 0.9
		3/4"	5 / 1	8 / 1	15 / 0.99	24 / 0.98	26 / 0.98	24 / 0.97	23 / 0.96
		7/8"	5 / 1	8 / 1	15 / 1	24 / 0.99	26 / 0.99	24 / 0.99	23 / 0.98
3.5 TON	3/8"	3/4"	5 / 1	8 / 0.99	15 / 0.98	24 / 0.97	24 / 0.97	21 / 0.96	20 / 0.95
		7/8"	5 / 1	8 / 1	15 / 0.99	24 / 0.99	24 / 0.99	21 / 0.98	20 / 0.98
4 TON	3/8"	3/4"	5 / 1	8 / 0.99	15 / 0.98	23 / 0.97	21 / 0.96	18 / 0.95	15 / 0.94
		7/8"	5 / 1	8 / 1	15 / 0.99	23 / 0.99	21 / 0.98	18 / 0.98	15 / 0.97
5 TON	3/8"	3/4"	5 / 1	8 / 0.99	15 / 0.97	20 / 0.95	14 / 0.94	9 / 0.92	5 / 0.9
		7/8"	5 / 1	8 / 0.99	15 / 0.99	20 / 0.98	14 / 0.97	9 / 0.96	5 / 0.96

**NOTES:**

- 1) Maximum Equivalent Line Length may not exceed 76 Meters.
- 2) Maximum Actual Line Length may not exceed 61 Meters.
- 3) Light Grey shaded areas are considered long line and may require accessories as recommended in Long Line Set Guide.
- 4) Refer to supplemental Long Line Set Guide for applications that require liquid line size other than 3/8".
- 5) **DO NOT** use suction line traps in the suction riser as this adds additional unwanted pressure drop in the system.

## Performance Data @ AHRI Standard Conditions – Cooling

DESIGNATED TESTED COMBINATION (DTC)													
OUTDOOR UNIT	AIR HANDLER	TOTAL CAPACITY BTU/H [kW]	NET SENSIBLE BTU/H [kW]	NET LATENT BTU/H [kW]	SEER2	EER2	INDOOR CFM [L/S]	47 DEGREE HEATING CAPACITY BTU/H [KW]	47 DEGREE COP	17 DEGREE HEATING CAPACITY BTU/H [KW]	17 DEGREE COP	REGION IV HSPF2	
(-)P15AZ18AJ2N	RH2TZ2417STANN	17,100 [5.0]	13,100 [3.8]	4,000 [1.2]	15.2	11.7	625 [295.0]	17,100 [5.0]	3.87	11,600 [3.4]	2.6	7.8	
(-)P15AZ24AJ2N	RH2TZ2417STANN	22,800 [6.7]	17,400 [5.1]	5,400 [1.6]	15.2	11.7	775 [365.8]	22,600 [6.6]	3.88	15,600 [4.6]	2.8	7.8	
(-)P15AZ30AJ2N	RH2TZ3617STANN	28,400 [8.3]	21,800 [6.4]	6,600 [1.9]	15.2	11.7	900 [424.8]	28,400 [8.3]	3.62	19,700 [5.8]	2.6	7.8	
(-)P15AZ36AJ2N	RH2TZ3617STANN	34,200 [10.0]	26,200 [7.7]	8,000 [2.3]	15.2	11.7	1,050 [495.5]	34,200 [10.0]	3.62	24,400 [7.2]	2.7	7.8	
(-)P15AZ42AJ2N	RH2TZ4821STANN	40,000 [11.7]	30,500 [8.9]	9,500 [2.8]	15.2	11.7	1,325 [625.3]	39,500 [11.6]	3.95	28,200 [8.3]	2.9	7.8	
(-)P15AZ48AJ2N	RH2TZ4821STANN	45,500 [13.3]	35,000 [10.3]	10,500 [3.1]	15.2	11.7	1,450 [684.3]	45,000 [13.2]	3.92	33,200 [9.7]	2.9	7.8	
(-)P15AZ60AJ2N	RH2TZ6024STANN	57,000 [16.7]	43,500 [12.7]	13,500 [4.0]	15.2	11.7	1,800 [849.5]	57,000 [16.7]	4.04	42,500 [12.5]	3.0	7.8	

**NOTE:** This data includes DTC (Designated Test Combination) ratings and is for reference purposes only. A full listing of official ratings and system match-ups, along with downloadable certificates, will be accessible from the AHRI website: [www.ahridirectory.org](http://www.ahridirectory.org) later this year.

[ ] Designates Metric Conversions

**GENERAL TERMS OF LIMITED WARRANTY\***

Manufacturer will furnish a replacement for any part of this product which fails in normal use and service within the applicable period stated, in accordance with the terms of the limited warranty.

**\*For complete details of the Limited and Conditional Warranties, including applicable terms and conditions, contact your local contractor or the Manufacturer for a copy of the product warranty certificate.**

Conditional Parts  
(Registration Required)..... Ten (10) Years

**Before proceeding with installation, refer to installation instructions packaged with each model, as well as complying with all Federal, State, Provincial, and Local codes, regulations, and practices.**